

PS/PSN Series

Rectangular type proximity sensor

Features

- Shorten the time of maintenance with the body
- Improved the noise resistance by adopting dedicated IC (DC 3-wire type)
- Reverse power polarity (DC), surge (DC/AC), overcurrent protection (DC type—Except for PS12 Series.)
- Long life cycle and high reliability
- Red LED status indication
- IP67 rated waterproof structure (IEC standard)
- Replacer for micro switches and limit switches



⚠ Please read "Caution for your safety" in operation manual before using.



Specifications

DC 3-wire type

※ The existing PS17 is upgraded its function and design and changed as PSN17.
 ※ The case color of PNP output type is changed from orange to gray.

Model	PS12-4DN PS12-4DP PS12-4DN2 PS12-4DNU PS12-4DPU PS12-4DN2U	PSN17-5DN PSN17-5DP PSN17-5DN2 PSN17-5DP2 PSN17-5DNU PSN17-5DPU PSN17-5DN2U PSN17-5DN-F	PSN17-8DN PSN17-8DP PSN17-8DN2 PSN17-8DNU PSN17-8DPU	PSN17-8DN-F PSN17-8DP-F PSN17-8DN2-F PSN17-8DNU-F PSN17-8DPU-F PSN17-8DN2U-F	PSN25-5DN PSN25-5DP PSN25-5DN2 PSN25-5DP2	PSN30-10DN PSN30-10DP PSN30-10DN2 PSN30-10DP2	PSN30-15DN PSN30-15DP PSN30-15DN2 PSN30-15DP2	PSN40-20DN PSN40-20DP PSN40-20DN2 PSN40-20DP2	PS50-30DN PS50-30DP PS50-30DN2 PS50-30DP2
Sensing distance	4mm ±10%	5mm ±10%	8mm ±10%		5mm ±10%	10mm ±10%	15mm ±10%	20mm ±10%	30mm ±10%
Hysteresis	Max. 10% of sensing distance								
Standard sensing target	12×12×1mm (Iron)	18×18×1mm (Iron)	25×25×1mm (Iron)			30×30×1mm (Iron)	45×45×1mm (Iron)	60×60×1mm (Iron)	90×90×1mm (Iron)
Setting distance	0~2.8mm	0~3.5mm	0~5.6mm	0~3.5mm	0~7mm	0~10.5mm	0~14mm	0~21mm	
Power supply (Operation voltage)	12~24VDC (1~30VDC)								
Current consumption	Max. 10mA								
Response frequency(*1)	500Hz	700Hz	200Hz	300Hz	250Hz	200Hz	100Hz	50Hz	
Residual voltage	Max. 1.5V								
Affection by Temp.	±10% Max. for sensing distance at +20℃ within temperature range of -25 ~ +70℃								
Control output	Max. 200mA								
Insulation resistance	Min. 50MΩ (at 500VDC mega)								
Dielectric strength	1500VAC 50/60Hz for 1minute								
Vibration	1mm amplitude at frequency of 10 ~ 55Hz in each of X, Y, Z directions for 2 hours								
Shock	500m/s ² (50G) in X, Y, Z direction for 3 times								
Indicator	Operation indicator (Red LED)								
Ambient temperature	-25 ~ +70℃ (at non-freezing status)								
Storage temperature	-30 ~ +80℃ (at non-freezing status)								
Ambient humidity	35 ~ 95%RH								
Protection circuit	Surge, Reverse power polarity protection circuit			Surge, Reverse power polarity, Overcurrent protection circuit					
Protection	IP67 (IEC standard)								
Cable spec.	φ 4 × 2P, 2m					φ 5 × 2P, 2m			
Approval	CE								
Unit weight	Approx. 62g	Approx. 71g	Approx. 70g		Approx. 111g	Approx. 158g	Approx. 220g		

※ (*1) The response frequency is the average value. The standard sensing target is used and the width is set as 2 times of the standard sensing target, 1/2 of the sensing distance for the distance.

Rectangular Type

■ Specifications

● DC 2-wire type

※The existing PS17 is upgraded its function and design and changed as PSN17.
 ※The case color of Normal Close type is changed from orange to gray.

Model	PSNT17-5DO PSNT17-5DC	PSNT17-5DOU PSNT17-5DCU
Sensing distance	5mm ±10%	
Hysteresis	Max. 10% of sensing distance	
Standard sensing target	18×18×1mm (Iron)	
Setting distance	0 ~ 3.5mm	
Power supply (Operating voltage)	24VDC (15~30VC)	
Leakage current	Max. 0.6mA	
Response frequency(*1)	700Hz	
Residual voltage	Max. 3.5V	
Affection by Temp.	±10% Max. for sensing distance at +20°C within temperature range of -25 ~ +70°C	
Control output	2~100mA	
Insulation resistance	Min. 50MΩ (at 500VDC mega)	
Dielectric strength	1500VAC 50/60Hz for 1 minute	
Vibration	1mm amplitude at frequency of 10 ~ 55Hz in each of X, Y, Z directions for 2 hours	
Shock	500m/s ² (50G) in X, Y, Z direction for 3 times	
Indicator	Operation indicator (Red LED)	
Ambient temperature	-25 ~ +70°C (at non-freezing status)	
Storage temperature	-30 ~ +80°C (at non-freezing status)	
Ambient humidity	35 ~ 95%RH	
Protection circuit	Surge protection circuit	
Protection	IP67 (IEC standard)	
Cable	φ 4×3P, 2m	
Approval	CE	
Unit weight	Approx. 69g	

※(*1) The response frequency is the average value. The standard sensing target is used and the width is set as 2 times of the standard sensing target, 1/2 of the sensing distance for the distance.

● AC 2-wire type

※The case color of Normal Close type is changed from orange to gray.

Model	PSN25-5AO PSN25-5AC	PSN30-10AO PSN30-10AC	PSN30-15AO PSN30-15AC	PSN40-20AO PSN40-20AC
Sensing distance	5mm ±10%	10mm ±10%	15mm ±10%	20mm ±10%
Hysteresis	Max. 10% of sensing distance			
Standard sensing target	25×25×1mm (Iron)	30×30×1mm (Iron)	45×45×1mm (Iron)	60×60×1mm (Iron)
Setting distance	0 ~ 3.5mm	0 ~ 7mm	0 ~ 10.5mm	0 ~ 14mm
Power supply (Operating voltage)	100~240VDC (85~264VC)			
Leakage current	Max. 2.5mA			
Response frequency(*1)	20Hz			
Residual voltage	Max. 10V			
Affection by Temp.	±10% Max. for sensing distance at +20°C within temperature range of -25 ~ +70°C			
Control output	5 ~ 200mA			
Insulation resistance	Min. 50MΩ (at 500VDC mega)			
Dielectric strength	2500VAC 50/60Hz for 1 minute			
Vibration	1mm amplitude at frequency of 10 ~ 55Hz in each of X, Y, Z directions for 2 hours			
Shock	500m/s ² (50G) in X, Y, Z direction for 3 times			
Indicator	Operation indicator (Red LED)			
Ambient temperature	-25 ~ +70°C (at non-freezing status)			
Storage temperature	-30 ~ +80°C (at non-freezing status)			
Ambient humidity	35 ~ 95%RH			
Protection circuit	Surge protection circuit			
Protection	IP67 (IEC standard)			
Cable	φ 4×2P, 2m	φ 5×2P, 2m		
Approval	CE			
Unit weight	Approx. 65g	Approx. 106g	Approx. 152g	

※(*1) The response frequency is the average value. The standard sensing target is used and the width is set as 2 times of the standard sensing target, 1/2 of the sensing distance for the distance.

(A)
Counter

(B)
Timer

(C)
Temp.
controller

(D)
Power
controller

(E)
Panel
meter

(F)
Tacho/
Speed/
Pulse
meter

(G)
Display
unit

(H)
Sensor
controller

(I)
Switching
power
supply

(J)
Proximity
sensor

(K)
Photo
electric
sensor

(L)
Pressure
sensor

(M)
Rotary
encoder

(N)
Stepping
motor &
Driver &
Controller

(O)
Graphic
panel

(P)
Production
stoppage
models &
replacement

PS/PSN Series

■ Dimensions

(Unit:mm)

●PS12

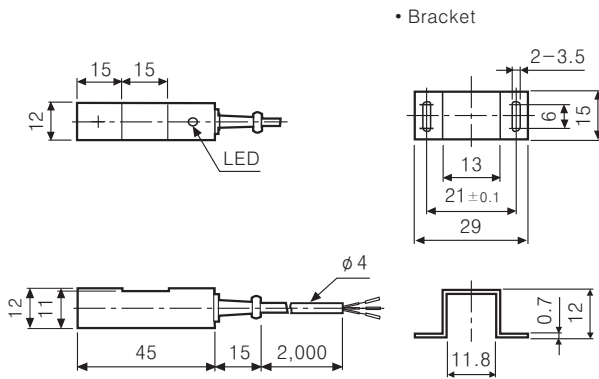

●PSN25

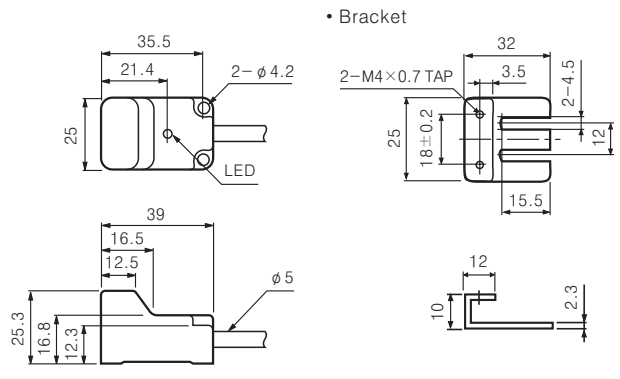

●PSN17 / PSNT17 (Former : PS17/ PST17)

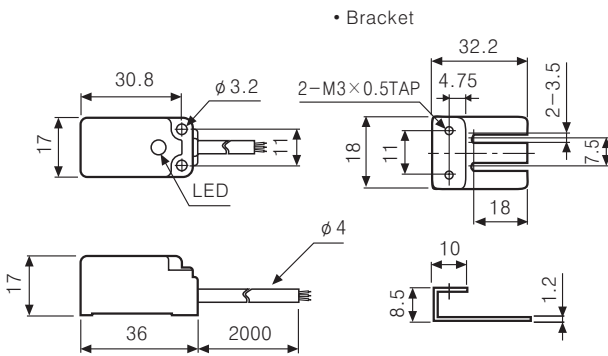

●PSN30

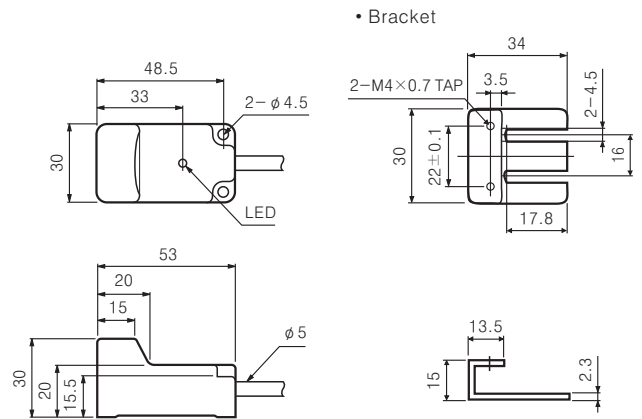

●PS50

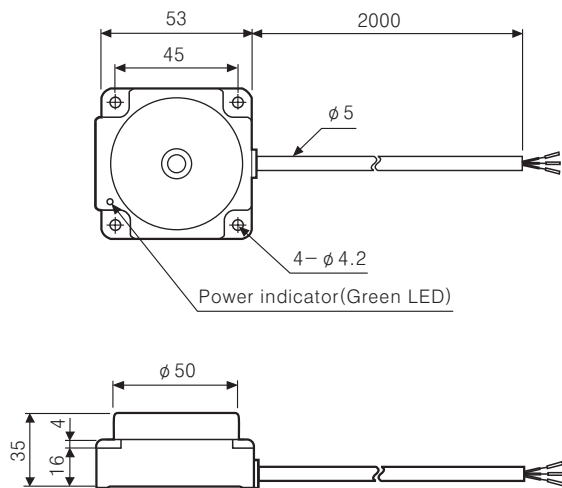

●PSN40

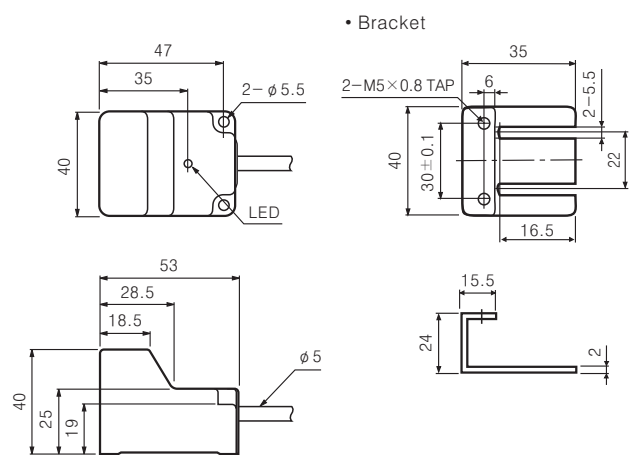

Rectangular Type

Control output diagram

DC 3-wire type

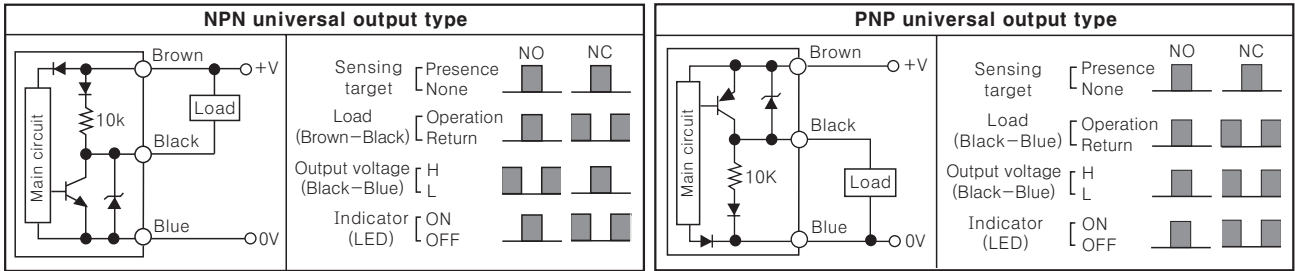

DC 2-wire type

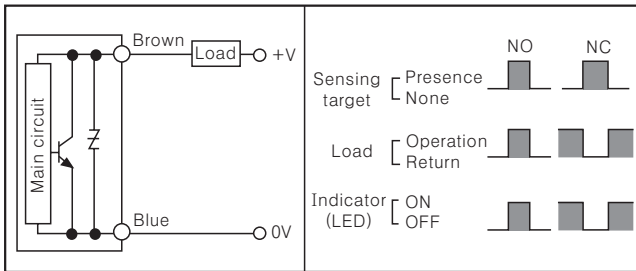

AC 2-wire type

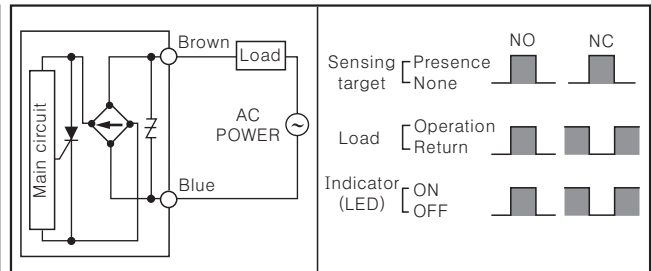

Connections

DC 3-wire type

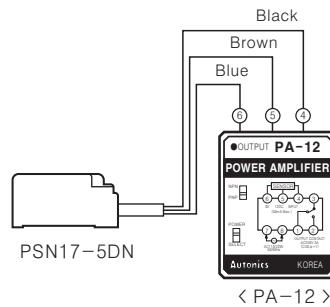
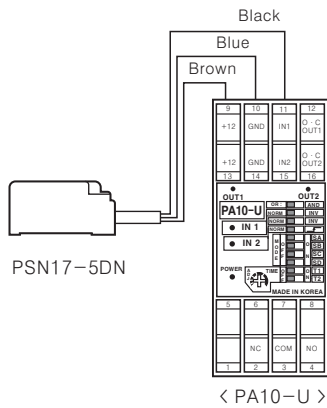

※ There is NPN/PNP selection switch in PA-12.

DC 2-wire type

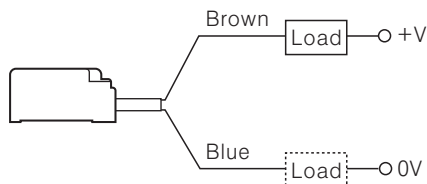

※ The load can be connected to either wire.

AC 2-wire type

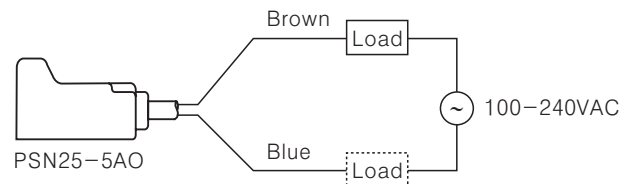

※ The load can be connected to either wire.

(A) Counter

(B) Timer

(C) Temp. controller

(D) Power controller

(E) Panel meter

(F) Tacho/Speed/Pulse meter

(G) Display unit

(H) Sensor controller

(I) Switching power supply

(J) Proximity sensor

(K) Photo electric sensor

(L) Pressure sensor

(M) Rotary encoder

(N) Stepping motor & Driver & Controller

(O) Graphic panel

(P) Production stoppage models & replacement

